

Part number:

HYDROMA

HYDRAULICKÉ SYSTÉMY

**HIDROMA
SYSTEMS**

UKŁADY HYDRAULICZNE

HYDROMA

ГИДРАВЛИЧЕСКИЕ СИСТЕМЫ

Gearboxes

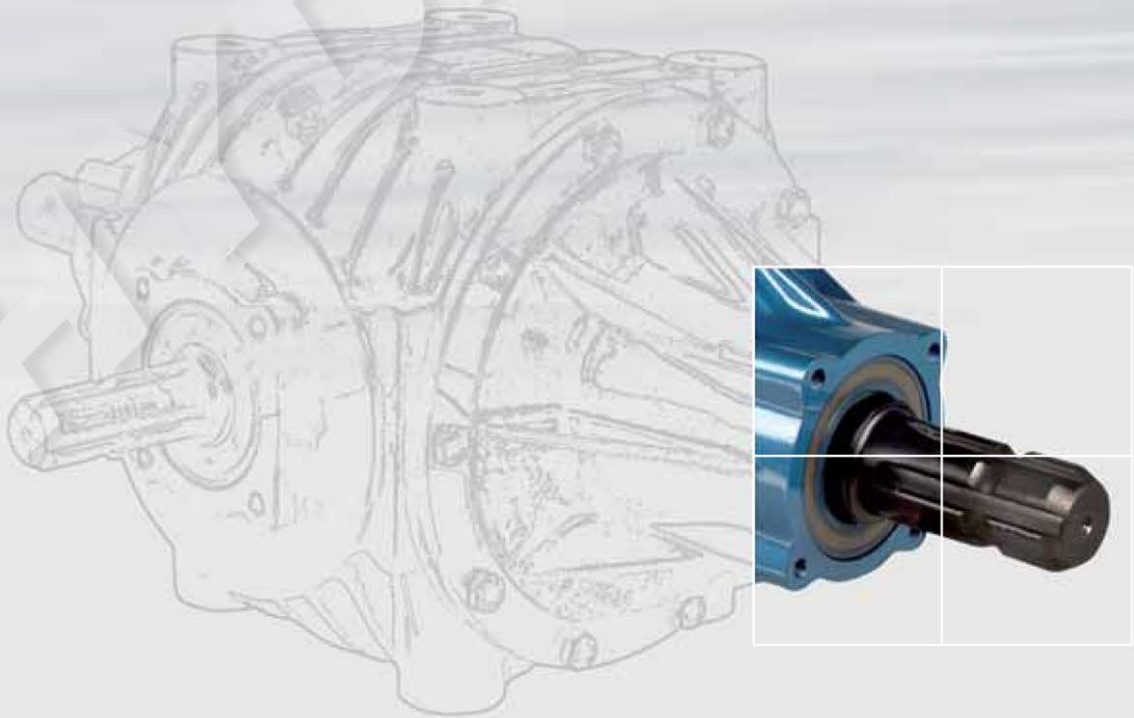



Tipo Macchina

Machine type

APPLICAZIONI VARIE - MISCELLANEOUS APPLICATIONS

	0.00
Applicazioni varie <i>Miscellaneous applications</i>	

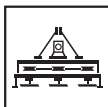

MACCHINE PER LA PREPARAZIONE DEL TERRENO - MACHINERY FOR LAND PREPARATION

	1.01		1.02		1.03		1.04
Trinciastocchi <i>Flail mowers</i>		Falciadistruggierba <i>Rotary mowers</i>		Decespugliatrici <i>Rotary cutters</i>		Spandiletame <i>Manure spreaders</i>	

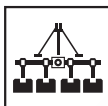



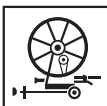

MACCHINE PER LA LAVORAZIONE DEL TERRENO - MACHINERY FOR SOIL TILLAGE

	2.01		2.02		2.03		2.04
Zappatrici - Fresatrici <i>Rotary tillers</i>		Zappatrici multiple <i>Multiple rotary tillers</i>		Ercipi rotanti <i>Vertical tillers</i>		Trivelle <i>Post hole diggers</i>	

MACCHINE PER IL TRATTAMENTO DELLE COLTURE - MACHINERY FOR PLANT AND CROP TREATMENT

	3.01		3.02		3.03		3.04
Atomizzatori <i>Sprayers</i>		Spandiconcime <i>Fertilizer spreaders</i>		Pompe centrifughe per irrigazione <i>Centrifugal pumps for irrigation</i>		Irrigatori a bobina <i>Irrigation reels</i>	

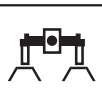

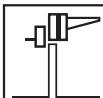



MACCHINE PER LA RACCOLTA, TRASFORMAZIONE E DISTRIBUZIONE DEL FORAGGIO
MACHINERY FOR HARVESTING, PROCESSING AND DISTRIBUTION OF FORAGE

 4.01	 4.02	 4.03	 4.04
Falciatrici rotative <i>Rotary mowers</i>	Giroandanatori <i>Rotary rakes</i>	Carri autocaricanti <i>Self loading trailers</i>	Presse raccogliatrici <i>Balers</i>
 4.05	 4.06	 4.07	
Spandifieno rotativi <i>Rotary tedders</i>	Desilatori <i>Silo unloaders</i>	Molini a martelli <i>Hammer mills</i>	

MACCHINE PER SERVIZI AUSILIARI - MACHINERY FOR AUXILIARY SERVICES











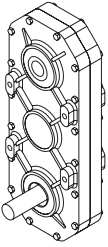

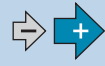



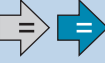



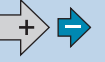

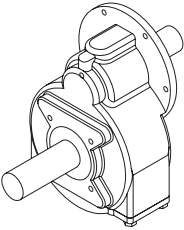





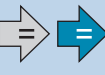





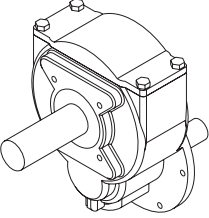





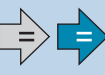



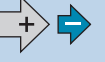

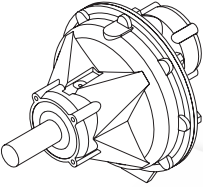

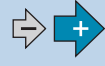



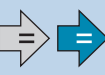





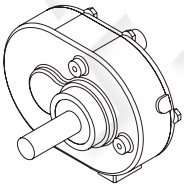

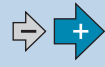



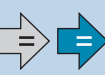



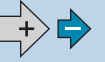

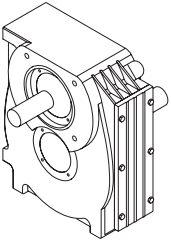

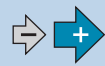
 5.01	 5.02	 5.03	
Gruppi elettrogeni <i>P.T.O. generators</i>	Seghe circolari - a nastro <i>Circular saws - Belt saws</i>	Pompe trituratrici per liquami <i>Lagoon pumps</i>	

Legenda - Legend

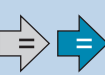



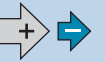





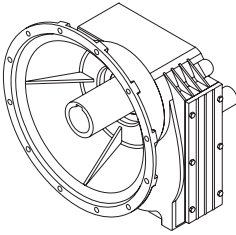

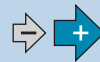



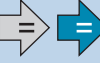



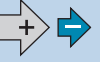

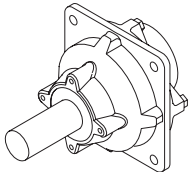

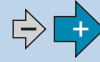







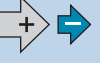

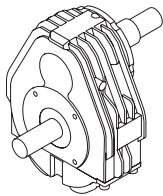

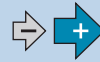









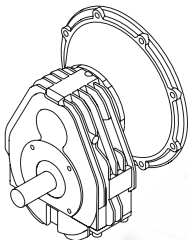





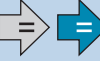





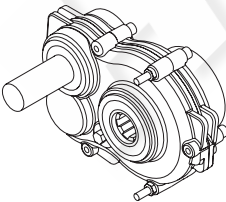





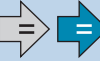



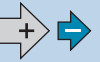

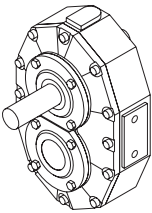

	Potenza in entrata <i>Input power</i>		Moltiplicatore <i>Speed increasing unit</i>
	Momento torcente in uscita <i>Output torque</i>		Rinvio <i>1:1 ratio</i>
	Giri in entrata <i>Input r.p.m.</i>		Riduttore <i>Reduction gear unit</i>

Scatole di ingranaggi ad assi paralleli

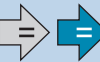
Parallel axes gearboxes



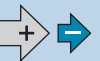







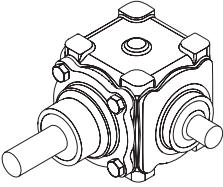

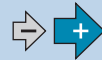







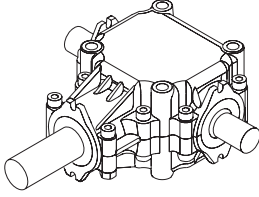









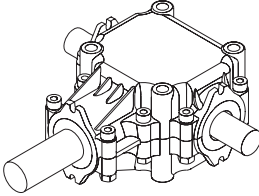







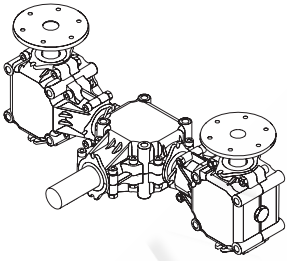







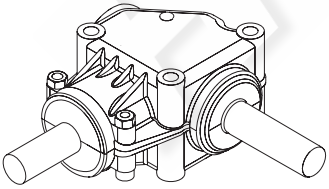

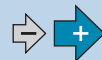

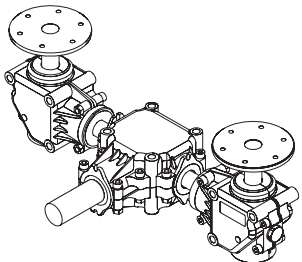

A-16A									
		[HP] [kW]	85.1 62.6			-			
		[daNm]	107.1			1.00			
		[rpm]	540			-			
A-1A									
		[HP] [kW]	5.0 - 16.0 3.7 - 11.8			7.80			
		[daNm]	2.5 - 49.1			-			
		[rpm]	540			7.80			
A-1B									
		[HP] [kW]	13.0 9.6			7.00			
		[daNm]	2.9			-			
		[rpm]	429			-			
A-20A									
		[HP] [kW]	75.0 55.2			1.88			
		[daNm]	50.3 - 96.0			-			
		[rpm]	540			1.88			
A-3A									
		[HP] [kW]	9.0 - 45.0 6.6 - 33.1			1.23 - 5.90			
		[daNm]	4.9 - 62.5			1.00			
		[rpm]	540			1.23 - 5.27			
A-4A									
		[HP] [kW]	12.0 - 90.0 8.8 - 64.0			1.48 - 7.00			
		[daNm]	10.8 - 109.4			1.00			
		[rpm]	540			1.48 - 7.00			

Scatole di ingranaggi ad assi paralleli
Parallel axes gearboxes

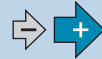









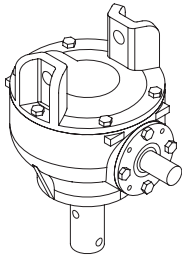

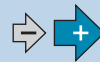

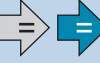

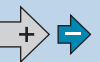
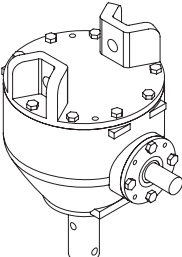

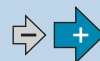

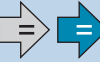



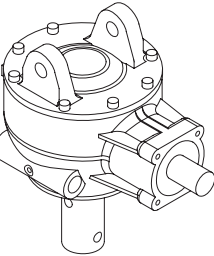

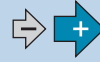



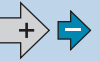
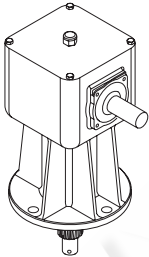

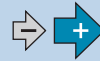



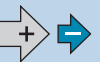
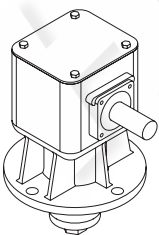



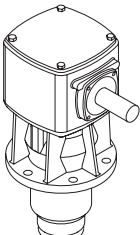

A-4F									
		[HP] [kW]	74.7 55.0			3.80			
		[daNm]	34.0			-			
		[rpm]	395			-			
A-623A									
		[HP] [kW]	10.1 - 14.9 7.4 - 11.0			1.60			
		[daNm]	11.8 - 20.1			-			
		[rpm]	540			1.60			
A-624A									
		[HP] [kW]	10.1 - 42.9 7.4 - 31.6			3.50 - 6.90			
		[daNm]	6.3 - 87.0			-			
		[rpm]	540			3.50 - 6.90			
A-624C									
		[HP] [kW]	29.9 - 40.8 22.0 - 30.0			3.50 - 6.90			
		[daNm]	6.8 - 18.5			-			
		[rpm]	429 - 435			-			
A-647A									
		[HP] [kW]	14.9 11.0			-			
		[daNm]	56.9			-			
		[rpm]	540			3.01			
MR-90									
		[HP] [kW]	42.9 - 87.0 31.6 - 64.0			1.90			
		[daNm]	57.7 - 107.1			1.00			
		[rpm]	540			1.90			

Scatole di ingranaggi ad assi ortogonali





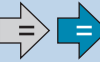





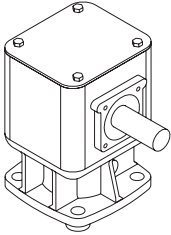

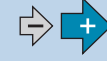

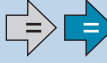

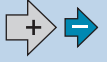
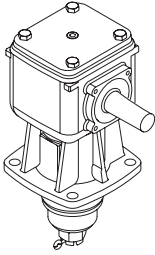

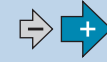





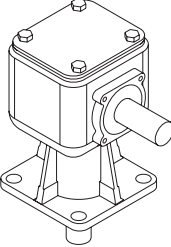

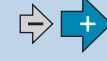





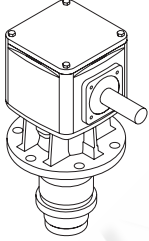







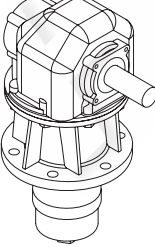



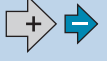
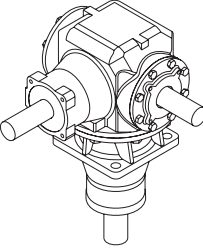

Right angle gearboxes

L-5A									
		[HP] [kW]	3.9 - 14.9 2.9 - 11.0			1.35 - 3.00			
		[daNm]	3.0 - 22.7			1.00			
		[rpm]	540			1.35 - 2.78			
L-25A									
		[HP] [kW]	3.0 - 14.9 2.2 - 11.0			1.35 - 2.91			
		[daNm]	3.1 - 22.7			1.00			
		[rpm]	540			1.35 - 3.30			
L-25B									
		[HP] [kW]	13.5 - 14.9 9.9 - 11.0			1.35			
		[daNm]	12.6 - 18.9			1.00			
		[rpm]	540			-			
L-25C									
		[HP] [kW]	14.9 11.0			1.35			
		[daNm]	12.6			-			
		[rpm]	540			-			
L-150B									
		[HP] [kW]	11.0 8.1			-			
		[daNm]	13.8			1.00			
		[rpm]	540			-			
L-150C									
		[HP] [kW]	13.5 9.9			1.35			
		[daNm]	12.6			-			
		[rpm]	540			-			

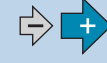









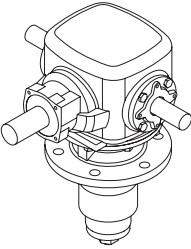

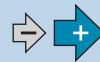

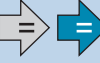

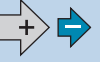
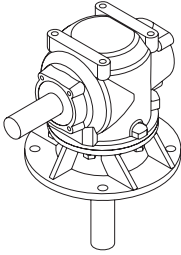

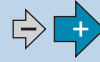

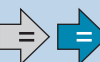

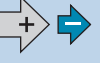
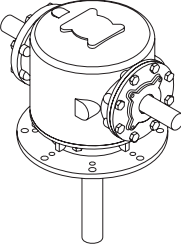



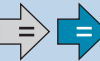



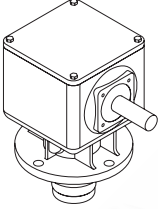





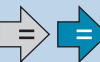

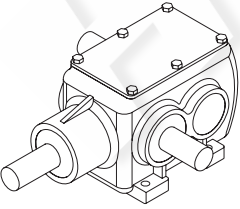



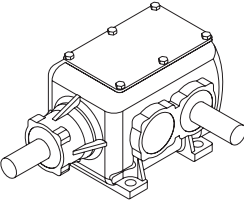

Scatole di ingranaggi ad assi ortogonali Right angle gearboxes

L-196J									
		[HP] [kW]	25.0 18.4			-	<input type="checkbox"/>	<input type="checkbox"/>	
		[daNm]	105.4			-		<input type="checkbox"/>	<input type="checkbox"/>
		[rpm]	540			3.18	<input type="checkbox"/>	<input type="checkbox"/>	<input type="checkbox"/>
L-212J									
		[HP] [kW]	29.9 22.0			-	<input type="checkbox"/>	<input type="checkbox"/>	
		[daNm]	159.1			-		<input type="checkbox"/>	<input type="checkbox"/>
		[rpm]	540			4.00	<input type="checkbox"/>	<input type="checkbox"/>	<input type="checkbox"/>
L-216J									
		[HP] [kW]	22.0 16.2			-	<input type="checkbox"/>	<input type="checkbox"/>	
		[daNm]	79.5			-		<input type="checkbox"/>	<input type="checkbox"/>
		[rpm]	540			3.00	<input type="checkbox"/>	<input type="checkbox"/>	<input type="checkbox"/>
LF-139A									
		[HP] [kW]	70.0 - 89.9 51.5 - 66.2			1.20 - 1.93	<input type="checkbox"/>		
		[daNm]	45.7 - 113.4			1.00	<input type="checkbox"/>	<input type="checkbox"/>	
		[rpm]	540			-	<input type="checkbox"/>	<input type="checkbox"/>	
LF-140A									
		[HP] [kW]	60.1 - 64.9 44.2 - 47.8			1.27 - 1.93	<input type="checkbox"/>		
		[daNm]	39.2 - 65.8			-	<input type="checkbox"/>	<input type="checkbox"/>	
		[rpm]	540			-	<input type="checkbox"/>	<input type="checkbox"/>	
LF-149B									
		[HP] [kW]	74.9 - 89.9 55.1 - 66.2			1.20 - 1.50	<input type="checkbox"/>		
		[daNm]	61.2 - 64.3			1.00	<input type="checkbox"/>	<input type="checkbox"/>	
		[rpm]	540			-	<input type="checkbox"/>	<input type="checkbox"/>	





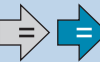





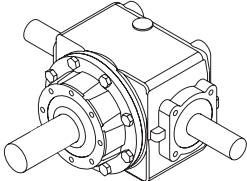

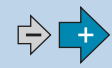

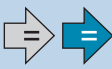

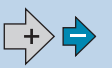
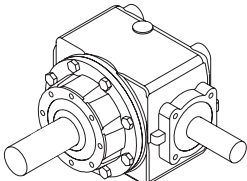

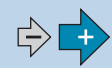



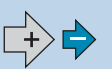
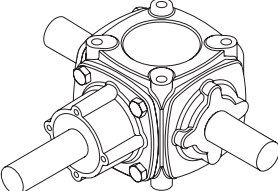







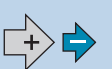
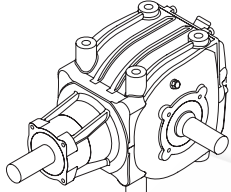

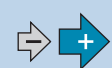



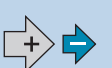
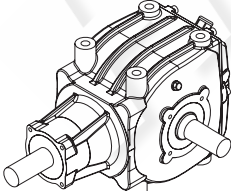



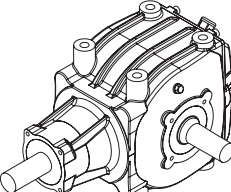

Scatole di ingranaggi ad assi ortogonali Right angle gearboxes

LF-151A								
		[HP] [kW]	45.0 - 48.0 33.1 - 35.3			2.54 - 3.00	<input type="checkbox"/>	
		[daNm]	18.9 - 23.8			-	<input type="checkbox"/>	<input type="checkbox"/>
		[rpm]	540			-	<input type="checkbox"/>	<input type="checkbox"/>
LF-205J								
		[HP] [kW]	30.0 - 39.9 22.1 - 29.4			1.47 - 1.92	<input type="checkbox"/>	
		[daNm]	19.7 - 34.3			-	<input type="checkbox"/>	<input type="checkbox"/>
		[rpm]	540			-	<input type="checkbox"/>	<input type="checkbox"/>
LF-211J								
		[HP] [kW]	20.0 - 21.1 14.7 - 15.5			2.50 - 2.83	<input type="checkbox"/>	
		[daNm]	8.9 - 12.2			-	<input type="checkbox"/>	<input type="checkbox"/>
		[rpm]	540			-	<input type="checkbox"/>	<input type="checkbox"/>
LF-227J								
		[HP] [kW]	74.9 55.1			1.22 - 1.83	<input type="checkbox"/>	
		[daNm]	51.7 - 77.5			1.00	<input type="checkbox"/>	<input type="checkbox"/>
		[rpm]	540			1.22	<input type="checkbox"/>	<input type="checkbox"/>
LF-32A								
		[HP] [kW]	60.1 44.2			1.50 - 1.93	<input type="checkbox"/>	
		[daNm]	39.2 - 50.4			1.00	<input type="checkbox"/>	<input type="checkbox"/>
		[rpm]	540			-	<input type="checkbox"/>	<input type="checkbox"/>
TF-26A								
		[HP] [kW]	89.9 66.2			1.85	<input type="checkbox"/>	
		[daNm]	61.3			-	<input type="checkbox"/>	<input type="checkbox"/>
		[rpm]	540			-	<input type="checkbox"/>	<input type="checkbox"/>











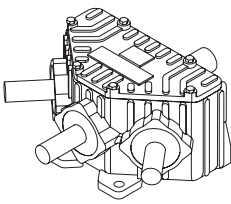







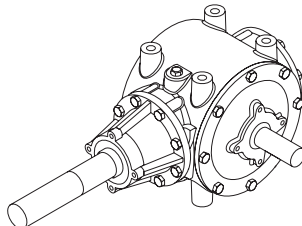







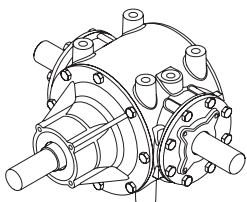









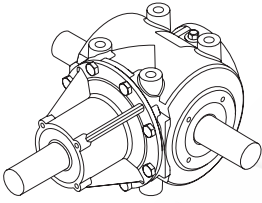







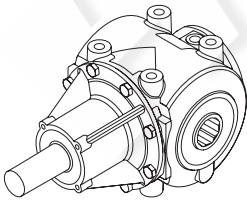



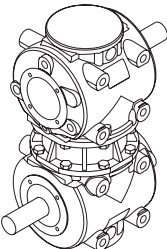

Scatole di ingranaggi ad assi ortogonali Right angle gearboxes

TF-285B									
		[HP] [kW]	114.9 84.6			1.86			
		[daNm]	77.9			-			
		[rpm]	540			-			
TV-21B									
		[HP] [kW]	22.0 16.2			-			
		[daNm]	53.2			-			
		[rpm]	540			1.92			
TV-274A									
		[HP] [kW]	80.0 58.9			-			
		[daNm]	194.7			-			
		[rpm]	540			1.93			
U10-100J									
		[HP] [kW]	101.4 74.6			1.22 - 1.83			
		[daNm]	68.6 - 103.0			-			
		[rpm]	540			1.22 - 1.46			
N-2A									
		[HP] [kW]	31.9 23.5			-			
		[daNm]	-			1.00			
		[rpm]	540			5.67			
N-698A									
		[HP] [kW]	54.9 40.4			-			
		[daNm]	-			1.00			
		[rpm]	540			5.70			











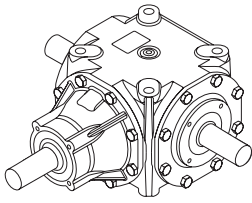

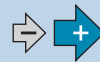



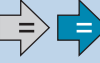



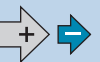

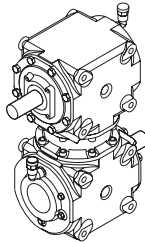

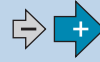



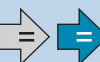



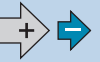

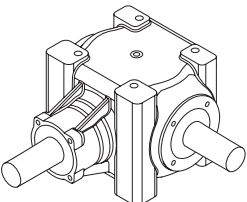









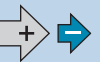

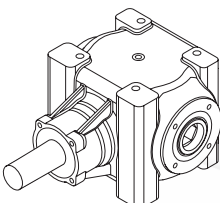













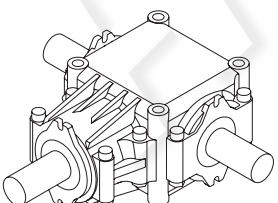













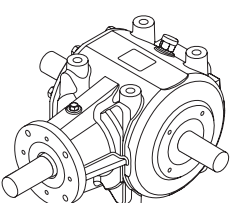



Scatole di ingranaggi ad assi ortogonali Right angle gearboxes

LV-221A									
		[HP] [kW]	44.8 33.0			-	<input type="checkbox"/>	<input type="checkbox"/>	
		[daNm]	101.1			-		<input type="checkbox"/>	<input type="checkbox"/>
		[rpm]	540			1.78	<input type="checkbox"/>	<input type="checkbox"/>	<input type="checkbox"/>
LZ-221F									
		[HP] [kW]	44.8 33.0			-	<input type="checkbox"/>	<input type="checkbox"/>	
		[daNm]	101.0			-		<input type="checkbox"/>	<input type="checkbox"/>
		[rpm]	540			1.78	<input type="checkbox"/>	<input type="checkbox"/>	<input type="checkbox"/>
T-19A									
		[HP] [kW]	5.00 - 33.0 3.7 - 24.3			1.46 - 2.91		<input type="checkbox"/>	
		[daNm]	4.5 - 41.6			1.00	<input type="checkbox"/>	<input type="checkbox"/>	
		[rpm]	540			1.46 - 2.91	<input type="checkbox"/>	<input type="checkbox"/>	<input type="checkbox"/>
T-22A									
		[HP] [kW]	20.0 - 98.0 14.7 - 72.1			1.93 - 6.14		<input type="checkbox"/>	
		[daNm]	10.2 - 200.5			-	<input type="checkbox"/>	<input type="checkbox"/>	
		[rpm]	540			1.93 - 6.14	<input type="checkbox"/>	<input type="checkbox"/>	<input type="checkbox"/>
TB-22C									
		[HP] [kW]	53.9 - 82.1 39.7 - 60.4			-	<input type="checkbox"/>	<input type="checkbox"/>	
		[daNm]	165.4 - 199.5			-		<input type="checkbox"/>	<input type="checkbox"/>
		[rpm]	540			1.93 - 2.43	<input type="checkbox"/>	<input type="checkbox"/>	<input type="checkbox"/>
TV-22D									
		[HP] [kW]	85.1 - 98.0 62.6 - 72.1			1.93 - 3.00	<input type="checkbox"/>	<input type="checkbox"/>	
		[daNm]	35.7 - 64.0			-	<input type="checkbox"/>	<input type="checkbox"/>	
		[rpm]	540			-	<input type="checkbox"/>		<input type="checkbox"/>











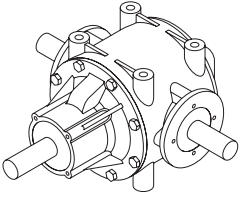

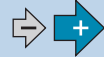



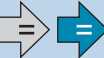

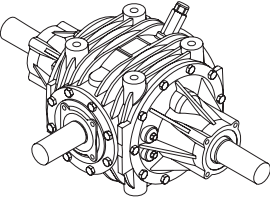







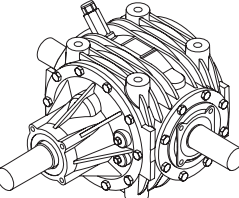









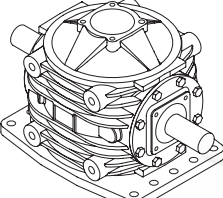







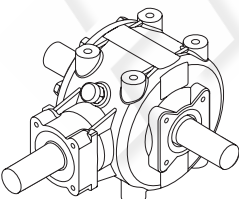





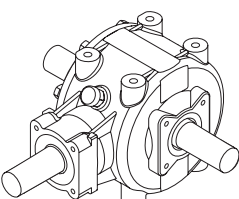

Scatole di ingranaggi ad assi ortogonali Right angle gearboxes

T-25A							
		[HP] [kW]	119.6 88.0			1.15	
		[daNm]	110.9			1.00	
		[rpm]	540			-	
T-269A							
		[HP] [kW]	89.9 - 105.0 66.2 - 77.3			1.42	
		[daNm]	93.2 - 161.1			1.00	
		[rpm]	540			1.42	
T-269B							
		[HP] [kW]	53.0 - 105.0 39.0 - 77.3			1.42 - 3.00	 
		[daNm]	35.7 - 200.5			-	
		[rpm]	540			1.42 - 3.00	
T-278A							
		[HP] [kW]	28.9 - 55.0 21.3 - 40.5			1.60 - 2.91	
		[daNm]	19.5 - 108.9			1.00	
		[rpm]	540			1.60 - 2.91	
TB-278C							
		[HP] [kW]	45.0 - 50.0 33.1 - 36.8			-	
		[daNm]	100.8 - 108.9			-	
		[rpm]	540			1.60 - 1.92	
T-278D							
		[HP] [kW]	60.1 44.2			1.35	
		[daNm]	56.0 - 75.6			1.00	
		[rpm]	540			-	

Scatole di ingranaggi ad assi ortogonali Right angle gearboxes











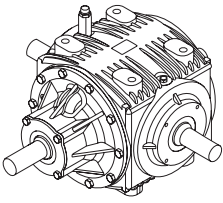

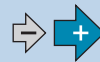



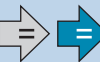

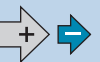
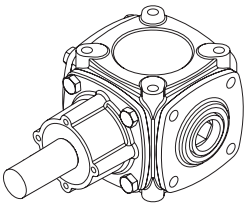

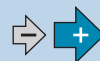

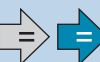



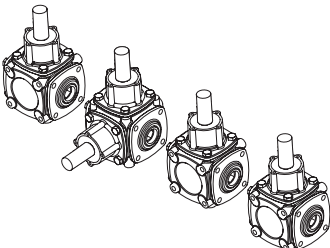







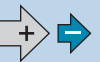
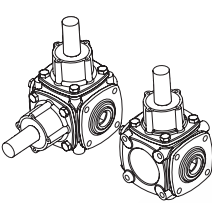







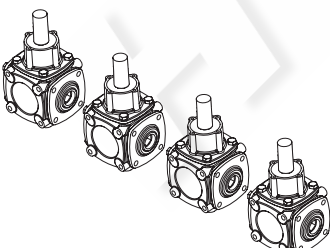



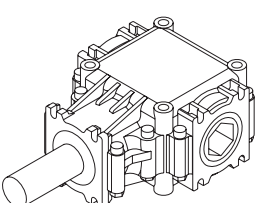

T-279A									
		[HP] [kW]	80.0 - 100.0 58.9 - 73.6			1.35 - 1.50			
		[daNm]	75.6 - 153.2			1.00			
		[rpm]	540			1.35 - 1.50			
T-279D									
		[HP] [kW]	85.1 - 100.0 62.6 - 73.6			1.35			
		[daNm]	79.4 - 126.0			1.00			
		[rpm]	540			-			
T-27A									
		[HP] [kW]	20.5 - 55.0 15.1 - 40.5			1.44 - 1.92			
		[daNm]	19.7 - 73.6			1.00			
		[rpm]	540			1.46 - 1.92			
TB-27C									
		[HP] [kW]	22.0 - 55.0 16.2 - 40.5			-			
		[daNm]	53.2 - 73.6			1.00			
		[rpm]	540			1.46 - 1.92			
T-281A									
		[HP] [kW]	5.0 - 23.0 3.7 - 16.9			1.46 - 2.91			
		[daNm]	4.7 - 29.4			1.00			
		[rpm]	540			1.46 - 2.91			
T-290A									
		[HP] [kW]	44.8 - 94.8 33.0 - 69.8			3.00 - 1.47			
		[daNm]	32.8 - 175.9			1.00			
		[rpm]	540			3.00 - 1.47			

Scatole di ingranaggi ad assi ortogonali Right angle gearboxes











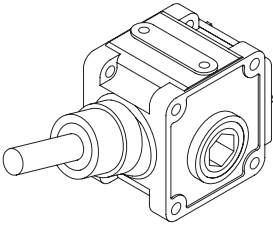

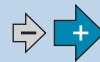

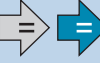

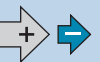

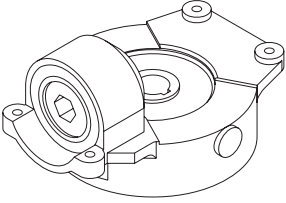

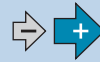



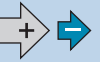

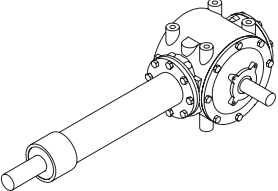





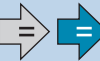

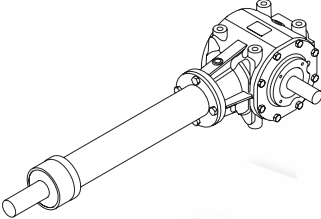





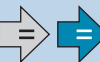

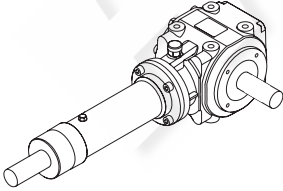

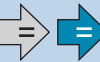

T-292B										
		[HP] [kW]	80.0 - 89.9 58.9 - 66.2			1.47 - 1.86				
		[daNm]	54.2 - 105.9			1.00				
		[rpm]	540			-				
T-301A										
		[HP] [kW]	104.9 - 139.8 77.2 - 102.9			1.35 - 1.93				
		[daNm]	71.9 - 255.5			-				
		[rpm]	540			1.35 - 1.93				
T-301B										
		[HP] [kW]	104.9 - 192.8 77.2 - 141.9			1.35 - 1.93				
		[daNm]	51.1 - 255.5			1.00				
		[rpm]	540 - 1000			1.35 - 1.93				
TV-301A										
		[HP] [kW]	99.9 73.5			-				
		[daNm]	252.0 - 321.0			-				
		[rpm]	540			1.93 - 2.42				
T-304A										
		[HP] [kW]	13.5 - 54.9 9.9 - 40.4			1.93 - 5.33				
		[daNm]	6.3 - 94.5			-				
		[rpm]	540			1.93 - 5.33				
T-304H										
		[HP] [kW]	25.0 18.4			-				
		[daNm]	94.5			-				
		[rpm]	540			3.00				

Scatole di ingranaggi ad assi ortogonali

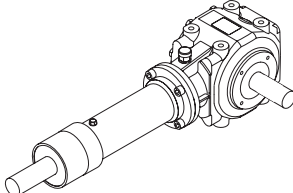

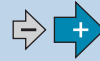



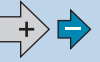



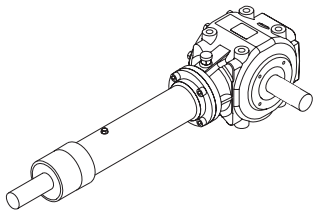

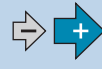



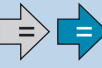





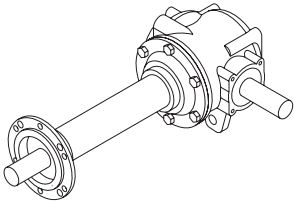

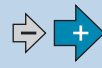



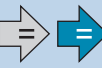





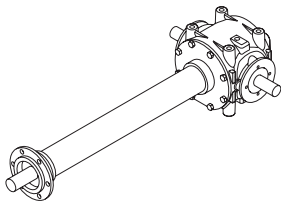

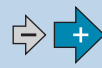



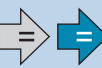





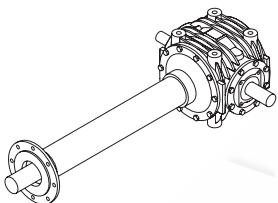

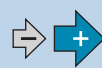
Right angle gearboxes

T-331A								
		[HP] [kW]	109.9 - 298.9 80.9 - 220.0			1.35 - 3.27		
		[daNm]	143.8 - 435.5			1.00		
		[rpm]	540			1.35 - 3.27		
TB-19C								
		[HP] [kW]	14.9 - 28.0 11.0 - 20.6			1.46		
		[daNm]	24.1 - 42.3			-		
		[rpm]	540			1.46 - 1.85		
TB-19H								
		[HP] [kW]	20.0 - 23.0 14.7 - 16.9			1.46		
		[daNm]	17.2			1.00		
		[rpm]	540			1.46		
TB-19I								
		[HP] [kW]	20.0 - 23.0 14.7 - 16.9			1.46		
		[daNm]	17.2			1.00		
		[rpm]	540			1.46		
TB-19L								
		[HP] [kW]	23.0 16.9			-		
		[daNm]	29.0			1.00		
		[rpm]	540			-		
TB-281B/C								
		[HP] [kW]	14.9 - 23.0 11.0 - 16.9			-		
		[daNm]	33.1 - 42.3			-		
		[rpm]	540			1.46 - 1.84		

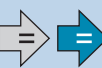









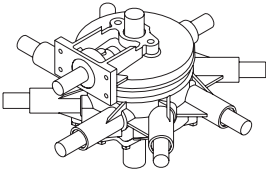

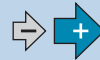





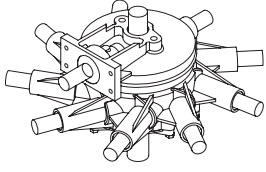







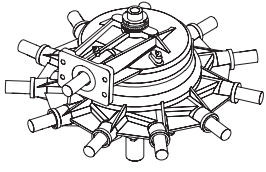







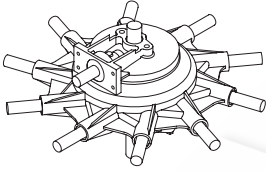

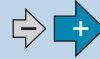





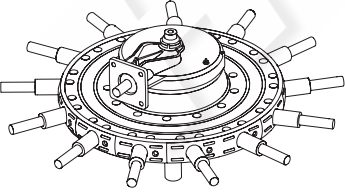



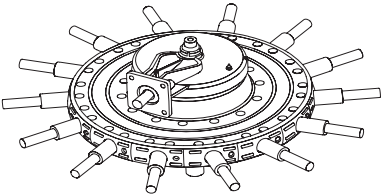

Scatole di ingranaggi ad assi ortogonali Right angle gearboxes

TB-318J								
		[HP] [kW]	27.2 20.0			-	<input type="checkbox"/>	<input type="checkbox"/>
		[daNm]	-			-	<input type="checkbox"/>	<input type="checkbox"/>
		[rpm]	540			1.77		<input type="checkbox"/>
TB-319J								
		[HP] [kW]	9.0 6.6			-	<input type="checkbox"/>	<input type="checkbox"/>
		[daNm]	-			-	<input type="checkbox"/>	<input type="checkbox"/>
		[rpm]	300			2.00		<input type="checkbox"/>
TL-269E								
		[HP] [kW]	89.9 - 110.1 66.2 - 81.0			1.42 - 2.42	<input type="checkbox"/>	
		[daNm]	46.9 - 97.6			-	<input type="checkbox"/>	<input type="checkbox"/>
		[rpm]	540			-	<input type="checkbox"/>	<input type="checkbox"/>
TL-290D								
		[HP] [kW]	77.9 - 129.9 57.3 - 95.6			1.47 - 3.00	<input type="checkbox"/>	
		[daNm]	32.8 - 60.2			-	<input type="checkbox"/>	<input type="checkbox"/>
		[rpm]	540			-	<input type="checkbox"/>	<input type="checkbox"/>
TL-310D								
		[HP] [kW]	29.9 - 59.0 22.0 - 43.4			1.60 - 3.00	<input type="checkbox"/>	
		[daNm]	12.6 - 26.1			-	<input type="checkbox"/>	<input type="checkbox"/>
		[rpm]	540			-	<input type="checkbox"/>	<input type="checkbox"/>
TL-311D								
		[HP] [kW]	49.9 - 77.9 36.7 - 57.3			1.60 - 3.00	<input type="checkbox"/>	
		[daNm]	21.0 - 35.9			-	<input type="checkbox"/>	<input type="checkbox"/>
		[rpm]	540			-	<input type="checkbox"/>	<input type="checkbox"/>











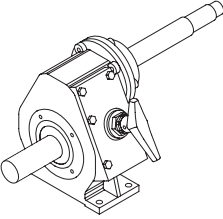







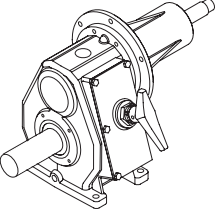







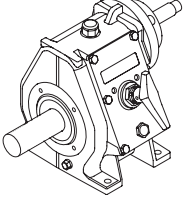







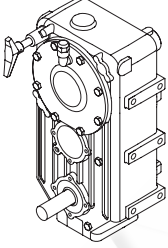







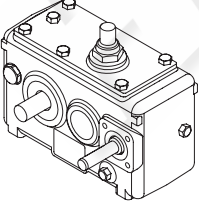



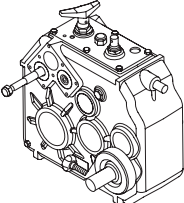

Scatole di ingranaggi ad assi ortogonali Right angle gearboxes

TL-312D								
		[HP] [kW]	62.0 - 103.9 45.6 - 76.5			1.60 - 3.00		
		[daNm]	26.1 - 47.7			-		
		[rpm]	540			-		
TLZ-21J								
		[HP] [kW]	23.9 - 39.9 17.6 - 29.4			-		
		[daNm]	58.1 - 73.6			-		
		[rpm]	540			1.46 - 1.92		
TLZ-292A								
		[HP] [kW]	64.9 47.8			-		
		[daNm]	155.5			-		
		[rpm]	540			1.86		
TLZ-301C								
		[HP] [kW]	89.7 - 114.8 66.0 - 84.5			-		
		[daNm]	232.0 - 274.0			-		
		[rpm]	540			1.60 - 2.42		







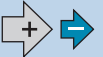



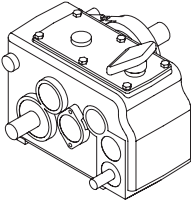

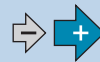

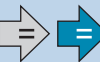

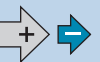
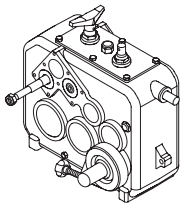

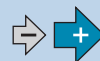

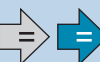



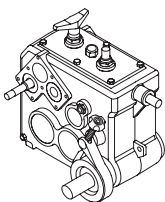







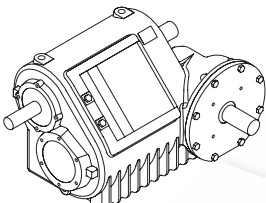







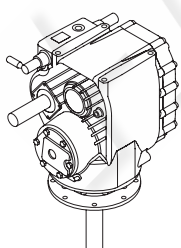



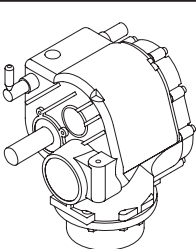

Giroandatori
Rotary rakes

K-789C								
		[HP] [kW]	-			-	<input type="checkbox"/>	<input type="checkbox"/>
		[daNm]	19.0			-	<input type="checkbox"/>	<input type="checkbox"/>
		[rpm]	540			6.80		<input type="checkbox"/>
K-791A								
		[HP] [kW]	-			-	<input type="checkbox"/>	<input type="checkbox"/>
		[daNm]	19.0			-	<input type="checkbox"/>	<input type="checkbox"/>
		[rpm]	540			6.80		<input type="checkbox"/>
K-792A								
		[HP] [kW]	-			-	<input type="checkbox"/>	<input type="checkbox"/>
		[daNm]	19.0			-	<input type="checkbox"/>	<input type="checkbox"/>
		[rpm]	540			7.20		<input type="checkbox"/>
K-794A								
		[HP] [kW]	-			-	<input type="checkbox"/>	<input type="checkbox"/>
		[daNm]	21.0			-	<input type="checkbox"/>	<input type="checkbox"/>
		[rpm]	540			8.20		<input type="checkbox"/>
K-795A								
		[HP] [kW]	-			-	<input type="checkbox"/>	<input type="checkbox"/>
		[daNm]	23.0			-	<input type="checkbox"/>	<input type="checkbox"/>
		[rpm]	540			9.70		<input type="checkbox"/>
K-796A								
		[HP] [kW]	-			-	<input type="checkbox"/>	<input type="checkbox"/>
		[daNm]	23.0			-	<input type="checkbox"/>	<input type="checkbox"/>
		[rpm]	540			9.70		<input type="checkbox"/>











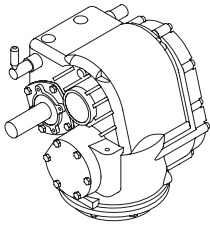

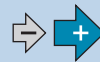

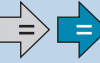

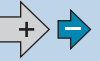
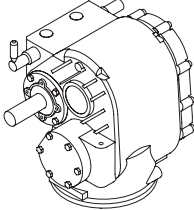



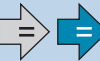

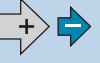
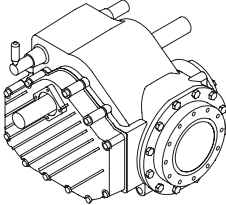



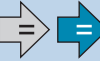



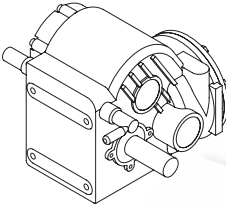



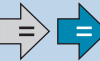

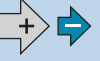
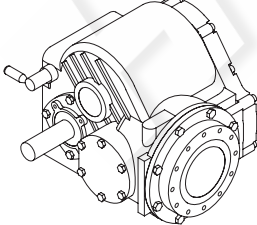

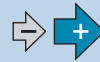
Cambi
Speed change gears

D-7B								
		[HP] [kW]	28.0 - 29.5 20.6 - 21.7			4.00 - 5.25	<input type="checkbox"/>	<input type="checkbox"/>
		[daNm]	6.7 - 9.3			-	<input type="checkbox"/>	
		[rpm]	540			-	<input type="checkbox"/>	<input type="checkbox"/>
D-21B								
		[HP] [kW]	55.0 - 56.0 40.5 - 41.2			2.95 - 4.53	<input type="checkbox"/>	<input type="checkbox"/>
		[daNm]	-			-	<input type="checkbox"/>	
		[rpm]	540			-	<input type="checkbox"/>	<input type="checkbox"/>
D-27B								
		[HP] [kW]	30.0 22.1			3.69 - 5.25	<input type="checkbox"/>	<input type="checkbox"/>
		[daNm]	-			-	<input type="checkbox"/>	
		[rpm]	540			-	<input type="checkbox"/>	<input type="checkbox"/>
D-732A								
		[HP] [kW]	80.0 58.9			-	<input type="checkbox"/>	<input type="checkbox"/>
		[daNm]	130.4 - 205.3			1.00	<input type="checkbox"/>	<input type="checkbox"/>
		[rpm]	540			1.93		<input type="checkbox"/>
D-741A								
		[HP] [kW]	-			-	<input type="checkbox"/>	<input type="checkbox"/>
		[daNm]	5.0			-	<input type="checkbox"/>	
		[rpm]	-			160.00	<input type="checkbox"/>	<input type="checkbox"/>
D-742A								
		[HP] [kW]	-			-	<input type="checkbox"/>	<input type="checkbox"/>
		[daNm]	200.0			-	<input type="checkbox"/>	
		[rpm]	-			116.00-756.00	<input type="checkbox"/>	<input type="checkbox"/>

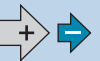
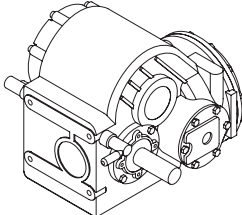

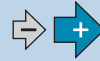



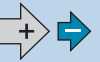



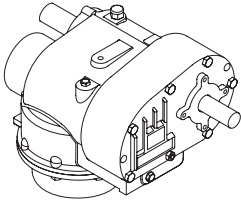

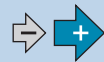

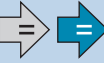

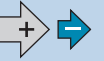
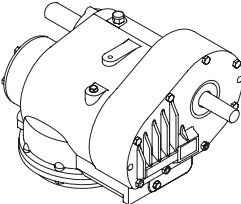

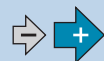





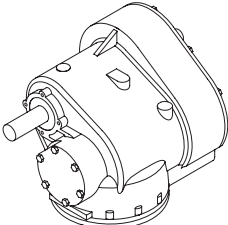

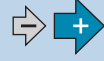



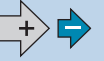
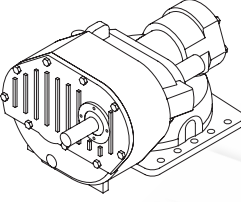

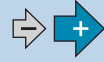



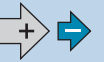
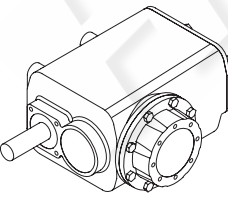

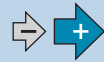

Cambi
Speed change gears

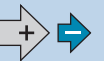
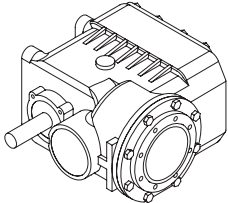
D-743A								
		[HP] [kW]	-			-	<input type="checkbox"/>	<input type="checkbox"/>
		[daNm]	25.0			-	<input type="checkbox"/>	
		[rpm]	-			97.00 - 631.00	<input type="checkbox"/>	<input type="checkbox"/>
D-744A								
		[HP] [kW]	-			-	<input type="checkbox"/>	<input type="checkbox"/>
		[daNm]	110.0			-	<input type="checkbox"/>	
		[rpm]	-			120.00-781.00	<input type="checkbox"/>	<input type="checkbox"/>
D-745A								
		[HP] [kW]	-			-	<input type="checkbox"/>	<input type="checkbox"/>
		[daNm]	60.0			-	<input type="checkbox"/>	
		[rpm]	-			117.00-766.00	<input type="checkbox"/>	<input type="checkbox"/>
D-825A								
		[HP] [kW]	298.9 220.0			-	<input type="checkbox"/>	<input type="checkbox"/>
		[daNm]	229.0 - 361.0			-		<input type="checkbox"/>
		[rpm]	1000			1.07 - 1.68	<input type="checkbox"/>	<input type="checkbox"/>
DV-733F								
		[HP] [kW]	179.8 132.3			-	<input type="checkbox"/>	<input type="checkbox"/>
		[daNm]	234.3 - 523.0			-		<input type="checkbox"/>
		[rpm]	1000			1.82 - 4.06	<input type="checkbox"/>	<input type="checkbox"/>
DV-813F								
		[HP] [kW]	70.0 51.5			-	<input type="checkbox"/>	<input type="checkbox"/>
		[daNm]	112.1 - 284.7			-		<input type="checkbox"/>
		[rpm]	540			1.21 - 3.06	<input type="checkbox"/>	<input type="checkbox"/>

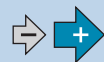
Cambi
Speed change gears











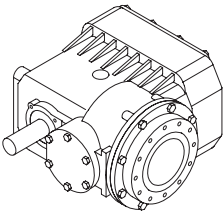

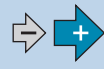
DV-818F									
		[HP] [kW]	94.8 69.8			-	<input type="checkbox"/>	<input type="checkbox"/>	
		[daNm]	156.7 - 402.4			-		<input type="checkbox"/>	<input type="checkbox"/>
		[rpm]	540			1.24 - 3.20	<input type="checkbox"/>	<input type="checkbox"/>	<input type="checkbox"/>
DV-823F									
		[HP] [kW]	129.9 95.6			-	<input type="checkbox"/>	<input type="checkbox"/>	
		[daNm]	215.4 - 489.8			-		<input type="checkbox"/>	<input type="checkbox"/>
		[rpm]	1.000			1.25 - 3.02	<input type="checkbox"/>	<input type="checkbox"/>	<input type="checkbox"/>
DZ-733F									
		[HP] [kW]	179.3 132.0			-	<input type="checkbox"/>	<input type="checkbox"/>	
		[daNm]	234.3 - 523.0			-		<input type="checkbox"/>	<input type="checkbox"/>
		[rpm]	1.000			1.82 - 4.06	<input type="checkbox"/>	<input type="checkbox"/>	<input type="checkbox"/>
DZ-811F									
		[HP] [kW]	70.0 51.5			-	<input type="checkbox"/>	<input type="checkbox"/>	
		[daNm]	112.1 - 284.7			-		<input type="checkbox"/>	<input type="checkbox"/>
		[rpm]	540			1.21 - 3.06	<input type="checkbox"/>	<input type="checkbox"/>	<input type="checkbox"/>
DZ-816F									
		[HP] [kW]	94.8 69.8			-	<input type="checkbox"/>	<input type="checkbox"/>	
		[daNm]	156.7 - 402.4			-		<input type="checkbox"/>	<input type="checkbox"/>
		[rpm]	540			1.24 - 3.20	<input type="checkbox"/>	<input type="checkbox"/>	<input type="checkbox"/>
DZ-821F									
		[HP] [kW]	129.9 95.6			-	<input type="checkbox"/>	<input type="checkbox"/>	
		[daNm]	215.4 - 489.8			-		<input type="checkbox"/>	<input type="checkbox"/>
		[rpm]	1.000			1.25 - 3.02	<input type="checkbox"/>	<input type="checkbox"/>	<input type="checkbox"/>

Cambi
Speed change gears

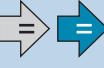



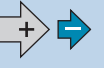





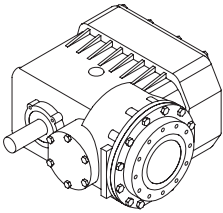

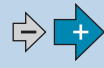
MV-814F									
		[HP] [kW]	70.0 51.5			-	<input type="checkbox"/>	<input type="checkbox"/>	
		[daNm]	112.1 - 284.7			-		<input type="checkbox"/>	<input type="checkbox"/>
		[rpm]	540			1.21 - 3.06	<input type="checkbox"/>	<input type="checkbox"/>	<input type="checkbox"/>
MV-819F									
		[HP] [kW]	94.8 69.8			-	<input type="checkbox"/>	<input type="checkbox"/>	
		[daNm]	156.7 - 402.4			-		<input type="checkbox"/>	<input type="checkbox"/>
		[rpm]	540			1.24 - 3.20	<input type="checkbox"/>	<input type="checkbox"/>	<input type="checkbox"/>
MV-824F									
		[HP] [kW]	129.9 95.6			-	<input type="checkbox"/>	<input type="checkbox"/>	
		[daNm]	215.4 - 489.8			-		<input type="checkbox"/>	<input type="checkbox"/>
		[rpm]	1.000			1.25 - 3.02	<input type="checkbox"/>	<input type="checkbox"/>	<input type="checkbox"/>
MV-826A									
		[HP] [kW]	199.7 147.0			-	<input type="checkbox"/>	<input type="checkbox"/>	
		[daNm]	373.1 - 456.0			-		<input type="checkbox"/>	<input type="checkbox"/>
		[rpm]	1.000			2.74 - 3.35	<input type="checkbox"/>	<input type="checkbox"/>	<input type="checkbox"/>
MZ-801F									
		[HP] [kW]	45.0 33.1			-	<input type="checkbox"/>	<input type="checkbox"/>	
		[daNm]	76.7 - 161.1			-		<input type="checkbox"/>	<input type="checkbox"/>
		[rpm]	540			1.29 - 2.73	<input type="checkbox"/>	<input type="checkbox"/>	<input type="checkbox"/>
MZ-812F									
		[HP] [kW]	70.0 51.5			-	<input type="checkbox"/>	<input type="checkbox"/>	
		[daNm]	112.1 - 284.7			-		<input type="checkbox"/>	<input type="checkbox"/>
		[rpm]	540			1.21 - 3.06	<input type="checkbox"/>	<input type="checkbox"/>	<input type="checkbox"/>

Cambi
Speed change gears

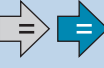



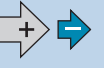





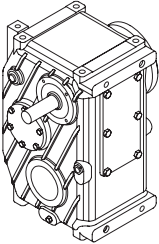

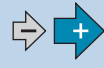
MZ-817F

		[HP] [kW]	94.8 69.8			-		
		[daNm]	156.7 - 402.4			-		
		[rpm]	540			1.24 - 3.20		

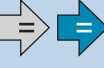



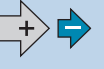





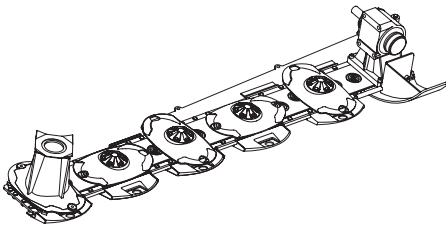

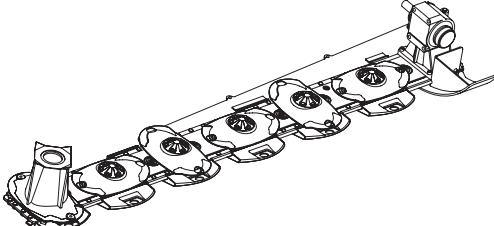
MZ-822F

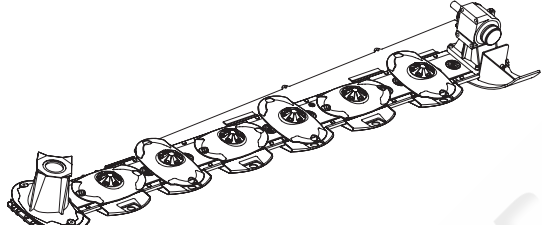
		[HP] [kW]	129.9 95.6			-		
		[daNm]	215.4 - 489.8			-		
		[rpm]	1.000			1.25 - 3.02		

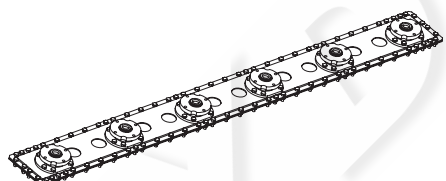
C-3A

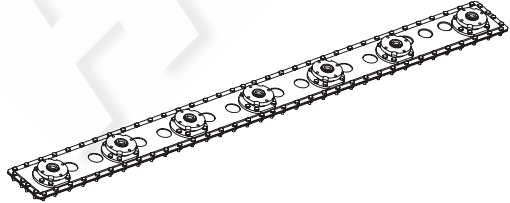
		[HP] [kW]	124.9 91.9			-		
		[daNm]	212.5 - 526.0			1.00		
		[rpm]	540			1.28 - 3.20		

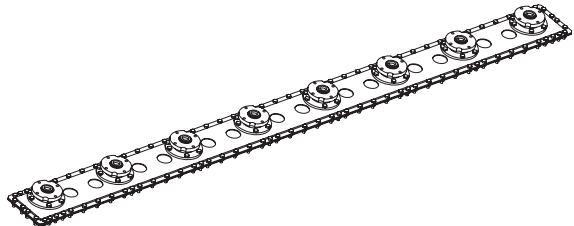
Barre falcianti
Cutter bars

FR-535A				
		[HP] [kW]	35.1 25.8	<input type="checkbox"/>
				<input type="checkbox"/>
FR-536A				
		[HP] [kW]	42.0 30.9	<input type="checkbox"/>
				<input type="checkbox"/>
FR-537A				
		[HP] [kW]	49.0 36.1	<input type="checkbox"/>
				<input type="checkbox"/>
FR-576A				
		[HP] [kW]	42.0 30.9	<input type="checkbox"/>
				<input type="checkbox"/>
FR-577A				
		[HP] [kW]	49.0 36.1	<input type="checkbox"/>
				<input type="checkbox"/>
FR-578A				
		[HP] [kW]	56.0 41.2	<input type="checkbox"/>
				<input type="checkbox"/>

Barre falcianti
Cutter bars

FR-579A

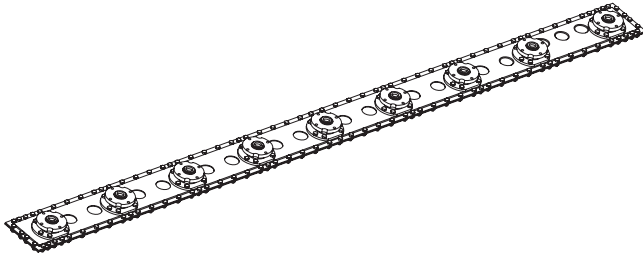

[HP]
[kW]



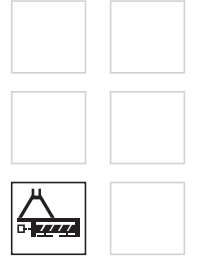



62.9
46.3



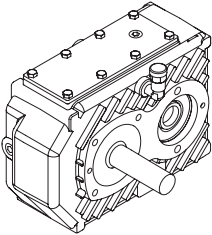





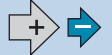

HYDROMIA

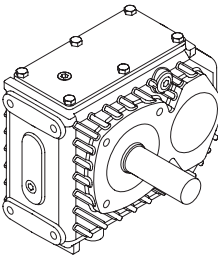
Applicazioni speciali
Special applications







A640

	 [HP] [kW]	59.8 44		 2.0 - 4.8	Decespugliatori Flail hedge mover
	 [daNm]	15.7 - 37.8		 -	
	 [rpm]	540		 -	

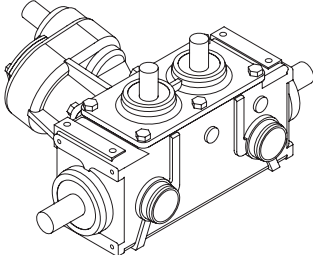



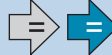

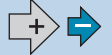

A649

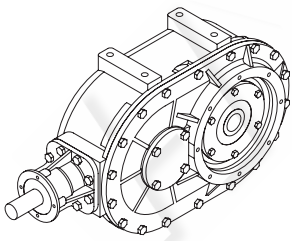
	 [HP] [kW]	103.3 76		 2.0 - 3.8	Decespugliatori Flail hedge mover
	 [daNm]	25.2 - 47.9		 -	
	 [rpm]	540		 -	







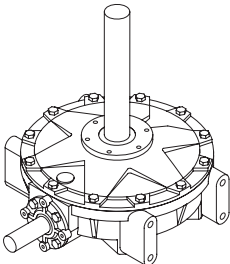

L170B

	 [HP] [kW]	12.0 8.8		 -	Mietitrebbia Combined harvester
	 [daNm]	-		 -	
	 [rpm]	-		 -	











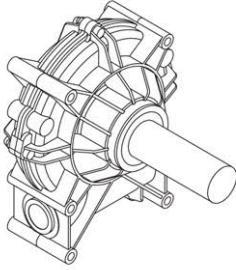



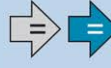

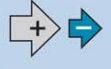
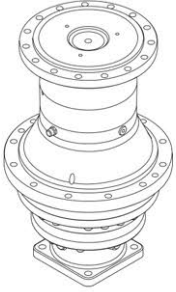







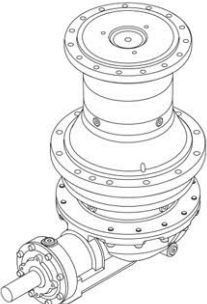

N673J

	 [HP] [kW]	74.9 55.1		 -	Betoniera Concrete mixer
	 [daNm]	1022		 -	
	 [rpm]	540		 10.8	

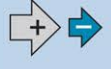
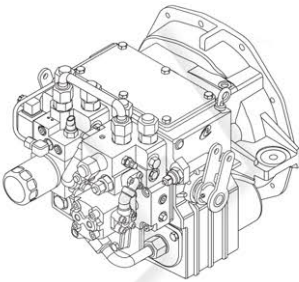
L154J

	 [HP] [kW]	39.9 29.4		 -	Betoniera Concrete mixer
	 [daNm]	391		 -	
	 [rpm]	540		 7.75	

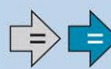
Applicazioni speciali
Special applications

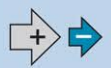
SG450A							
		[HP] [kW]	-			-	Smonta gomme Tyre changer
		[daNm]	40			-	
		[rpm]	580			100	
PG1600							
		[HP] [kW]	-			-	Carro miscelatore Feed mixer
		[daNm]	1600			-	
		[rpm]	540			13.4 - 21.1	
PGA1600							
		[HP] [kW]	-			-	Carro miscelatore Feed mixer
		[daNm]	1600			-	
		[rpm]	540			13.4 - 21.1	
HT481							
		[HP] [kW]	33 25			-	Tosaerba Lawn mover
		[daNm]	-			-	
		[rpm]	3200			1,37 (P.T.O.)	